



The directive 2014/34/EU

ATEX derives its name from ATMosphere EXposable and stands for the Directive 2014/34/EU of the European Parliament. The Directive concerns electrical and non-electrical equipment and protection systems for use in potential explosive atmospheres. Since 1st of July 2003, devices and protection systems for use in potentially explosive areas must satisfy the new Directive 94/9/EC. This directive has been replaced by 2014/34/EU since 20th of April 2016.

ATEX classifies explosive atmospheres and associates equipment

Problem:	Plant evaluation acc. to ATEX directive 99/92/EC		Equipment evaluation according to ATEX directive 2014/34/EU	
Guarantor:	Equipment manufacturer		AIRTEC Pneumatic GmbH	
Outcome:	Zone classification		Equipment group	
	- Temperature class - Explosion group - Ambient temperature		- Temperature class - Explosion group - Ambient temperature	

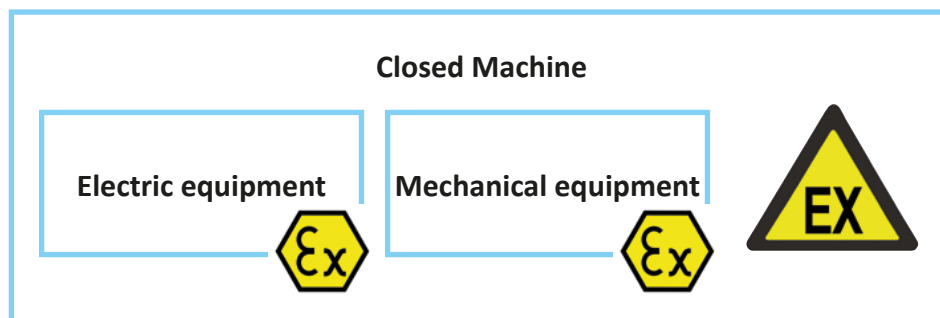

Zone and category

Zone classification reflects the likelihood of the occurrence of an explosive atmosphere. Furthermore, differentiation is made as to whether the hazard is due to gases, vapour and mists or due to dust.

The category indicates in which zone the equipment is suitable.

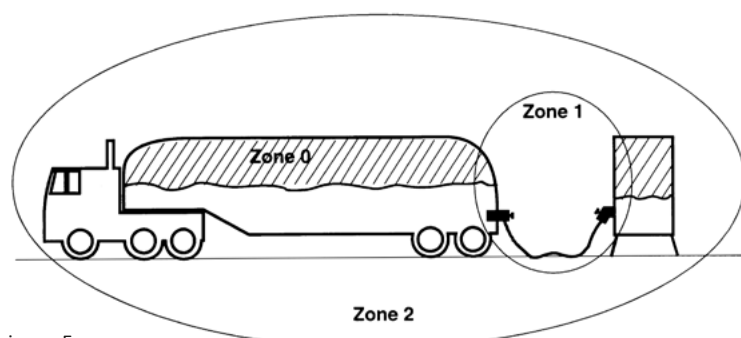

Example of zone classification in gas Ex area

Equipments are divided in 2 groups. Group I is subdivided in category M1 and M2 and specifies the use of which equipment can be used in underground mining works.

All further equipment is classified into Group II.

Group II is divided in Category 1, 2 and 3.

Category 1: Equipment in this category is characterised by a very high degree of safety and is specified in Zone 0 and 20.

Category 2: Equipment in this category is characterised by a high degree of safety and is specified in Zone 1 and 21

Category 3: Equipment in this category affords the necessary degree of safety in normal operation and is specified in Zone 2 and 22



General information

Overview Zones und Categories

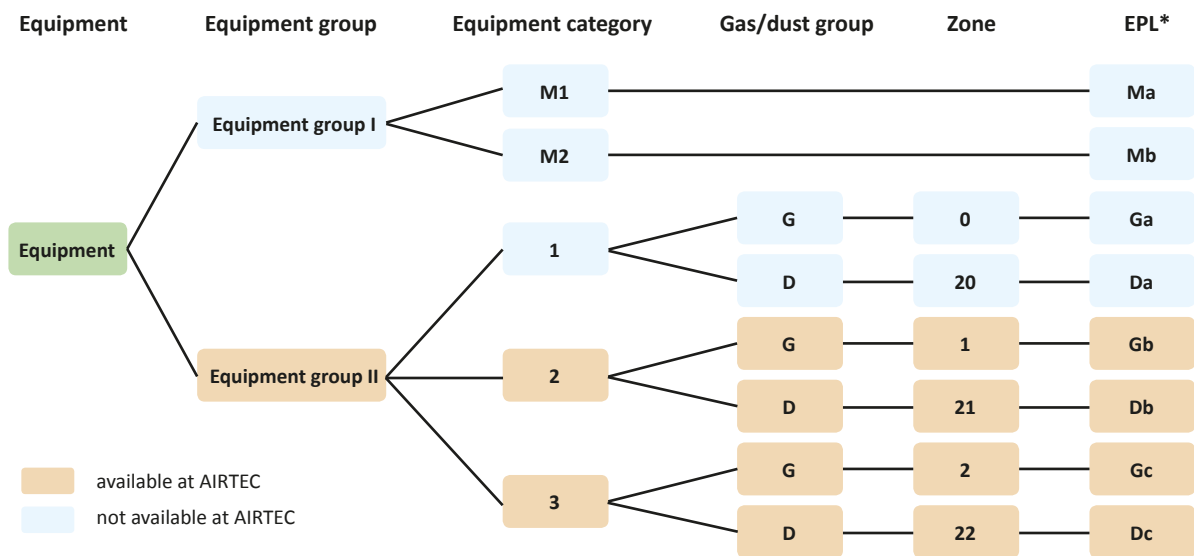

* EPL = Equipment protection level

Equipment category 1

Devices in Equipment category 1 guarantee a very high level of safety. They are designed for areas, in which an explosive gas atmosphere is present continuously, frequently or for long periods. Devices in this category can also be used in Equipment category 2 and 3.

Category 1G	Category 1D
Devices for use in Zone 0	Devices for use in Zone 20
Inflammable gases, vapors or mists	Inflammable dusts
An area in which an explosive gas atmosphere is present continuously, frequently or for long periods. Equipment protection level Ga, very high level of safety.	An area in which an explosive dust atmosphere, in the form of a cloud of dust in air, is present continuously, frequently or for long periods. Equipment protection level Da, very high level of safety.

Equipment category 2

Devices in Equipment category 2 guarantee a high level of safety. They are designed for areas, in which an explosive gas atmosphere is likely to occur periodically or occasionally in normal operation. Devices in this category can also be used Equipment category 3.

Category 2G	Category 2D
Devices for use in Zone 1	Devices for use in Zone 21
Inflammable gases, vapors or mists	Inflammable dusts
An area in which an explosive gas atmosphere is likely to occur periodically or occasionally in normal operation. Equipment protection level Gb, high level of safety.	An area in which an explosive dust atmosphere, in the form of a cloud of dust in air, is likely to occur in normal operation occasionally. Equipment protection level Db, high level of safety.

Equipment category 3

Devices in Equipment category 3 guarantee a normal level of safety. They are designed for areas, in which an explosive gas atmosphere is not likely to occur in normal operation but, if it does occur, it will exist for a short period only.

Category 3G	Category 3D
Devices for use in Zone 2	Devices for use in Zone 22
Inflammable gases, vapors or mists	Inflammable dusts
An area in which an explosive gas atmosphere is not likely to occur in normal operation but, if it does occur, it will exist for a short period only. Equipment protection level Gc, normal level of safety.	An area in which an explosive dust atmosphere, in the form of a cloud of combustible dust in air, is not likely to occur in normal operation but, if it does occur, will persist for a short period only. Equipment protection level Dc, normal level of safety.



Equipment protection level

EPL Ga or Da

Equipment with a very high protection level for use in hazardous areas. In normal operation this equipment represents no risk of ignition in the event of predictable or rare faults/malfunctions.

EPL Gb or Db

Equipment with a high protection level for use in hazardous areas which represents no risk of ignition in normal operation or in the event of predictable faults/malfunctions.

EPL Gc or Dc

Equipment with an advanced protection level for use in hazardous areas. There is no risk of ignition during normal operation. The equipment has additional protective measures that ensure no risk of ignition in the event of typically predictable equipment faults.

Temperature class

It must be ensured that the ignition temperature of an inflammable material is not reached during operation. For this purpose, the maximum surface temperature of a device must be less than the minimum ignition temperature. For this reason, the maximum surface temperature of equipment for use with inflammable gases, vapors or mists is specified in temperature classes. For dusty environments, the maximum surface temperature is specified in °C.

Temperature class	Maximum permissible surface temperature of the device
T1	450°C
T2	300°C
T3	200°C
T4	135°C
T5	100°C
T6	85°C



General information

Device marking



II 2G Ex h IIC T5 Gb
II 2D Ex h IIIC T100°C Db

1. row

marking according to RL 2014/34/EU

- II** Equipment group: II Equipment for hazardous areas - apart from mining
- 2G** Equipment category: 2 for Zone 1 and G for gases

marking according to DIN EN ISO 80079-36

- Ex** abbreviation for explosion protection
- h** Symbol for ignition protection class: h is representative for 6 different ignition protection classes h can be e.g. constructional safety c, flameproof enclosure d, pressurised enclosure p etc.
- IIC** Explosion group II = gases
The device group II is sub-divided into explosion group A, B and C. The subdivision is indicating the gap width of a technical device. C indicates the highest and A the lowest requirement class.
The selection of the explosion is depending of the media and the correspondent explosion group requirement.
- T5** Temperature class: T5 assignment of gases and vapors accordance to the ignition temperature > 100°C
- Gb** Equipment protection level (EPL) G = gases b = Equipment with a high protection level for use in hazardous areas which represents no risk of ignition in normal operation or in the event of predictable faults/malfunctions.
suitable for zone 1

2. row

marking according to RL 2014/34/EU

- II** Equipment group: II Equipment for hazardous areas - apart from mining
- 2D** Equipment category: 2 for Zone 1 and D for dust Zone 21

marking according to DIN EN ISO 80079-36

- Ex** abbreviation for explosion protection
- h** Symbol for ignition protection class: h is representative for 6 different ignition protection classes h can be e.g. constructional safety c, flameproof enclosure d, pressurised enclosure p etc.
- IIIC** Explosion group III = Inflammable dusts, fluff
C is indicating the type of dust for which the equipment is suitable. Additionally it's divided in A: flammable suspended materials, B: flammable suspended materials and non-conductive dusts and C: flammable suspended materials and conductive dusts.
- T100°C** maximum permissible surface temperature
- Db** Equipment protection level (EPL) D = dust b = Equipment with a high protection level for use in hazardous areas which represents no risk of ignition in normal operation or in the event of predictable faults/malfunctions.
suitable for zone 21



Mechanically operated valves

Device marking

Mechanically operated valves are marked as follows:

II 2GD c T6 T85°C *
 -10°C Tamb +60°C

* Marking according to DIN EN 13463-1/-5 valid until 30.10.2019, thereafter according to DIN EN ISO 80079-36/-37.

Mechanically operated valves conform to Equipment category 2 and can be used in Zone 1 respectively Zone 21.

Available valves

Series	Versions
HF-12	310, 510, 530, 533
HF-14	310, 510, 530, 533
HF-18	310, 510, 530, 533
HR-12	320, 520, 530, 533

Series	Versions
HR-14	320, 520, 530, 533
HR-18	320, 520, 530, 533
T-28	311
T-30	310, 510

Pneumatically operated valves

Device marking

Pneumatically operated valves are marked as follows:

II 2GD c T5 T100°C *
 -10°C Tamb +50°C

* Marking according to DIN EN 13463-1/-5 valid until 30.10.2019, thereafter according to DIN EN ISO 80079-36/-37.

Pneumatically operated valves conform to Equipment category 2 and can be used in Zone 1 respectively Zone 21.

Available Valves

Series	Versions
L-25	311, 320, 511, 520
L-28	311, 320, 511, 520
P-05	311, 320, 511, 520, 530, 533, 534
P-07	311, 320, 511, 520, 530, 533, 534
P-12	311, 320, 511, 520, 530, 533, 534
PI-01	511, 520
PI-02	511, 520, 530, 533, 534
PI-03	511, 520, 530, 533, 534

Series	Versions
PKX-09	511, 520
PKX-10	511, 520, 530
PN-05	311, 511, 520, 530
PNX-55	311, 511, 520



The operating instructions for the valve must be taken into account before putting into operation. These are included with each valve and are available at www.airtec.de.



Valves Electrically operated

Device marking

Electrically operated valves are marked as follows:



* Marking according to DIN EN 13463-1/ -5 valid until 30.10.2019, thereafter according to DIN EN ISO 80079-36/ -37.



Electrically operated valves conform to equipment category 2 can be used in Zone 1 respectively in Zone 21. For the use in hazardous areas the category group of the used coil has to be taken into account. The specification of the whole equipment corresponds always to the lowest category of the single components.

Available valves

Series	Versions	Series	Versions
KM-09	510, 511, 520, 530, 533, 534	ME-05	311, 320, 511, 520
KM-10	510, 511, 520, 530, 533, 534	ME-07	311, 320, 511, 520
KMX-09	511, 520	MO-05	311
KMX-10	511, 520, 530	MO-07	311
KN-05	310, 311, 510, 511, 520, 530, 533, 534	MO-22	310, 311
KN-55	311, 511	MI-01	511, 520, 530, 533
KNX-55	311, 511, 520	MI-02	511, 520, 530, 533
M-04	310, 510, 511, 520, 530, 533	MI-03	511, 520, 530, 533
M-05	310, 311, 510, 511, 520, 530, 533, 534	MN-06	310, 311, 510, 511, 520, 530
M-07	310, 311, 510, 511, 520, 530, 533, 534	MS-18	310
M-22	310, 311, 510, 511, 520, 530, 533		



The use of special electrical equipment and operators requires in certain cases a design change of the valve. All changes are shown on the following pages.

For the NAMUR valve as well the body dimension is different to standard. Please see below.

KN-05, MN-06 Divergent dimensions

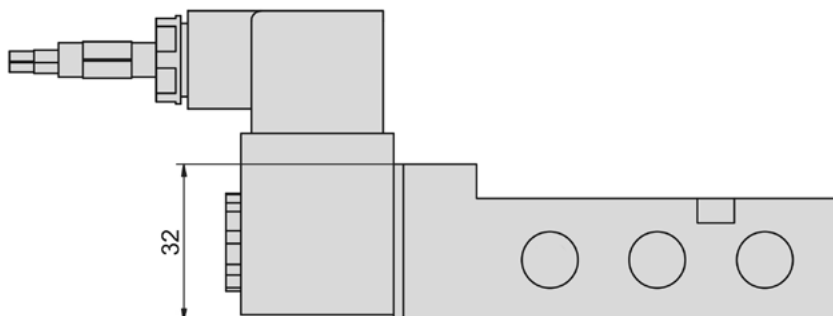

The operating instructions for the valve and the electrical equipment must be taken into account before putting into operation. These are included with each valve and are available at www.airtec.de.

Solenoid coils
23-SP-036

Ignition protection class	Encapsulated with casting compound mb (gases) mb tb (dust)
Classification	II 2G Ex mb IIC T4 II 2D Ex mb tb IIIC T130°C IP65
Overall width	22 mm
Temperature range*	-20°C...+50°C (battery fitted -20°C...+40°C)
Temperature range medium	-10°C...+50°C (battery fitted -10°C...+40°C)

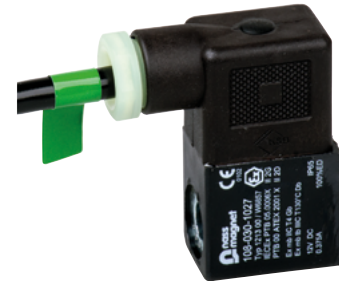

* The max. applicable operating temperature depends on the temperature specification of the used valve.

Model-no.:	23-SP-036-011-03	23-SP-036-012-03
Voltage	12 V DC	24 V DC
Power consumption	4.5 W	5 W
Rated current	375 mA	207 mA
Connecting cable	3 m	3 m

23-SP-037

Ignition protection class	Encapsulated with casting compound mb (gases) mb tb (dust)
Classification	II 2G Ex mb IIC T5 II 2D Ex mb tb IIIC T95°C IP65
Overall width	30 mm
Temperature range*	-20°C...+50°C (battery fitted -20°C...+40°C)
Temperature range medium	-10°C...+50°C (battery fitted -10°C...+40°C)



* The max. applicable operating temperature depends on the temperature specification of the used valve.

Model-no.:	23-SP-037-012-xx	23-SP-037-025-xx	23-SP-037-027-xx
Voltage	24 V DC	110...120 V AC	230 V AC
Power consumption	3.3 W	3 VA	3.1 VA
Rated current	136 mA	27 mA	14 mA
Connecting cable (xx)	03 = 3 m, 05 = 5 m, 10 = 10 m	03 = 3 m, 05 = 5 m, 10 = 10 m	03 = 3 m, 05 = 5 m, 10 = 10 m

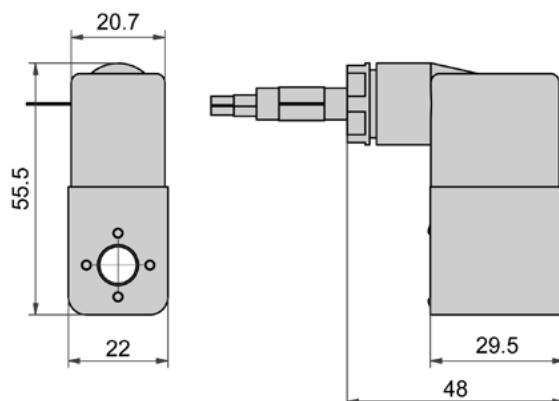
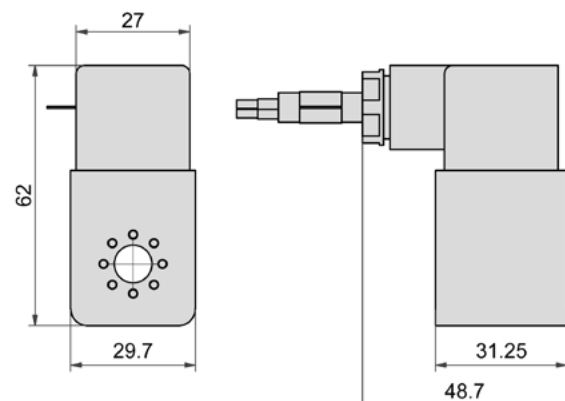
Dimensions
23-SP-036

23-SP-037



Valves Electrically operated

Solenoid coils

23-SP-038

Ignition protection class	Intrinsically safe ia (gases) t (dust)
Classification	II 2G Ex ia IIC T6 Ga (≤ 28 V DC) II 2G Ex ia IIB T6 Ga (≤ 32 V DC) II 2D Ex t IIIC T80°C Db IP65
Overall width	30 mm
Temperature range*	-40°C...+50°C
Temperature range medium	-10°C...+50°C (battery fitted -10°C...+40°C)



* The max. applicable operating temperature depends on the temperature specification of the used valve.

Model-no.:	23-SP-038-01-912
Voltage	$U \leq 28$ V DC / $U \leq 32$ V DC
Rated current	$I \leq 115$ mA / $I \leq 195$ mA
Rated current	375 mA
Connection	plug (part of delivery)

23-SP-040

Ignition protection class	Non-sparking device na (gases) tc (dust)
Classification	II 3G Ex nA IIC T6 Gc II 3D Ex tc IIIC T95°C Dc IP65
Overall width	30 mm
Temperature range*	-20°C...+50°C
Temperature range medium	-10°C...+50°C (battery fitted not allowed)



* The max. applicable operating temperature depends on the temperature specification of the used valve.

Model-no.:	23-SP-040-B12	23-SP-040-B27
Voltage	24 V DC	230 V AC
Power consumption	2.7 W	4 VA
Rated current	112 mA	15...18 mA
Connection	plug (part of delivery)	plug (part of delivery)

Dimensions

23-SP-038

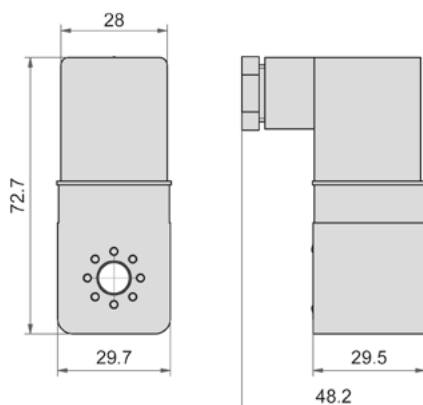

23-SP-040

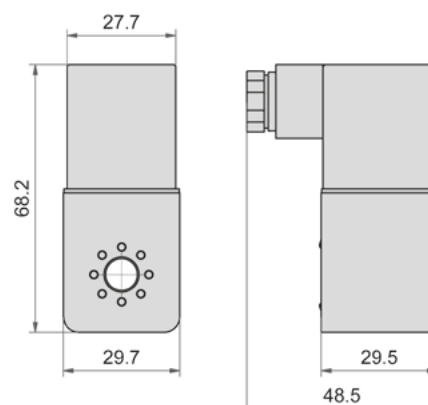



Function valves

Device marking

Mechanically operated valves according ATEX are marked with following suffix:

-ATEX

Classification

 II 2GD c T6 T85°C *
-10°C Tamb +50°C

* Marking according to DIN EN 13463-1/ -5 valid until 30.10.2019, thereafter according to DIN EN ISO 80079-36/ -37.
Function valves conform to Equipment category 2 and can be used in Zone 1 respectively Zone 21.

Available valves

Series	Versions
SE	SE-18, SE-14, SE-12



Cylinders

Piston rod cylinders

Device marking

Piston rod cylinders according ATEX are marked with following suffix:

-ATEX
-EX
-X

Classification

 **II 2GD c T5 T100°C ***
-20°C Tamb +80°C

* Marking according to DIN EN 13463-1/ -5 valid until 30.10.2019, thereafter according to DIN EN ISO 80079-36/ -37.

The equipment is according category 2 and can be used in zone 1 and zone 21.

Available cylinders

Series	Versions
XL	XL, XLH
	XLC (-40°C Tamb +80°C)
XG	XG, XGH (only up to Ø 200 mm)
HM	HM, HMP, HMDE, HMPDE
CM	CM, CMP, CMDE, CMPDE

Classification

 **II 2GD c T4 T120°C ***
-20°C Tamb +80°C

* Marking according to DIN EN 13463-1/ -5 valid until 30.10.2019, thereafter according to DIN EN ISO 80079-36/ -37.

The equipment is according category 2 and can be used in zone 1 and zone 21.

Available cylinders

Series	Versions
XM	XM, XM4, XMH, XM4H
NYD	Ø 20 and 25 with 5 ... 60 mm stroke, Ø 32 up to 100 with 5 ... 80 mm stroke
NYE	5, 10, 15, 20 and 25 mm stroke
NYDK	NYDK2, NYDK3, NYDK4
NYM	MYM2AG, NYM2IG, NYM3AG, NYM3IG
NYR2	NYR2



The operating instructions for the cylinder must be taken into account before putting into operation. These are included with each cylinder and are available at www.airtec.de.



Rodless cylinders series ZX

Device marking

ZX-cylinder are marked as follows:

 II 2GD c T6 T85°C -10°C ≤ Tamb ≤ 60°C

The equipment is according category 2 and can be used in zone 1 and zone 21.

Available rodless cylinders

ZX ZX-Ø-S, ZX-Ø-K, ZX-Ø-SG, ZX-Ø-KG, ZX-Ø-SR, ZX-Ø-KR,



The operating instructions for the cylinder must be taken into account before putting into operation. These are included with each cylinder and are available at www.airtec.de.



Accessories

Accessories for valves

The valves are intended to be used with the following accessories:

Accessories	series
Manifolds	R-181/n, R-281/n, R-141/n
Manifolds	RF-09/n, RF-10/n
Blind plates	RF-181-V, RF-281-V, R-141-V, RF-09-V, RF-10-V
Mounting brackets	R-181-W, R-281-W, R-141-W

Accessories for piston rod cylinders

The cylinders are intended to be used with the following accessories:



Accessories	series
Flexible coupling	FK-∅
Rod eye	FO-∅, RO-∅, PO-∅ (v_{max} 1 m/s)
Rod clevis	FD-∅, RD-∅, PD-∅
Piston rod nut	FE-∅, RL-∅, PL-∅
Mounting accessories XL	XLB-∅-01, XLB-∅-02, XLB-∅-03, XLB-∅-04, XLB-∅-05, XLB-∅-06, XLB-∅-07, XLB-∅-08, XLB-∅-09, XLB-∅-10, XLB-∅-11, XLB-∅-12, XLB-∅-13, XLB-∅-14,
Mounting accessories XG	VLB-∅-01, VLB-∅-02, VLB-∅-03, VLB-∅-04, VLB-∅-05, VLB-∅-06, VLB-∅-08, VLB-∅-09, VLB-∅-12
Mounting accessories HM	RA-∅, RC-∅, RG-∅, RH-∅, RB-∅, RM-∅
Mounting accessories CM	PA-∅, PC-∅, PB-∅, PM-∅

Accessories for rodless cylinders

The cylinders are intended to be used with the following accessories:

Accessories	series
Mounting accessories ZX	ZXB-∅-01, ZXB-∅-02, ZXB-∅-10, ZXB-∅-20

Proximity switches

Model-No.	Classification / Identification marking
ZS-7300	 II 3G Ex nA T4 II 3D Ex tD A22 IP67 T 125°C
ZS-7302	 II 3D Ex tc IIIC T125°C Dc X



The operating instructions for the equipment must be taken into account before putting into operation. These are available at www.airtec.de.